



Job: _____

Item No. _____

DESIGNED FOR LOW VOLUME APPLICATIONS

Two 3 oz. Servings per minute – 7 Quart Capacity

ECONOMICAL IN PRICE & SPACE!

The **SaniServ** model DF200 Soft Serve/Yogurt Freezer is ideal for providing small servings, samplers, and adding a-la-mode to favorite desserts. Economical in price and space, **DuraFreeze** offers the prospect for high profits and customer satisfaction.

SPACE SAVING

Small Footprint Design - SaniServ DuraFreeze 200 saves valuable floor space and turns the countertop into a real profit center by serving high profit ice cream and yogurt products.

EASY CLEANING AND OPERATION

Fewer Parts = Simplified Cleaning – SaniServ equipment is designed and built with the fewest parts to be disassembled, cleaned and sanitized than any other machine in the industry.

HIGH RETURN ON INVESTMENT

Increased Profits – SaniServ machines combine affordable efficiency with consistent product quality and fast, quiet operation to insure customer satisfaction with high profit frozen beverages.

QUALITY DESIGN

Durability – SaniServ machines are built to achieve long and dependable life through simplicity of design. Every machine is shipped standard with a stainless steel exterior, durable construction, heavy-duty components and consistency systems.

Model DF200

Counter Model

Soft Serve

Ice Cream / Yogurt Machine

DuraFreeze



Made in USA

We reserve the right to change specifications and product designs without notice. Such revisions do not entitle the buyer to corresponding changes, improvements, additions or replacements for previously purchased equipment.

MODEL DF200

Counter Model Soft Serve/Yogurt Machine

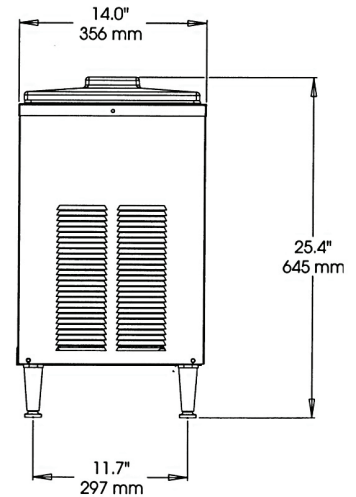
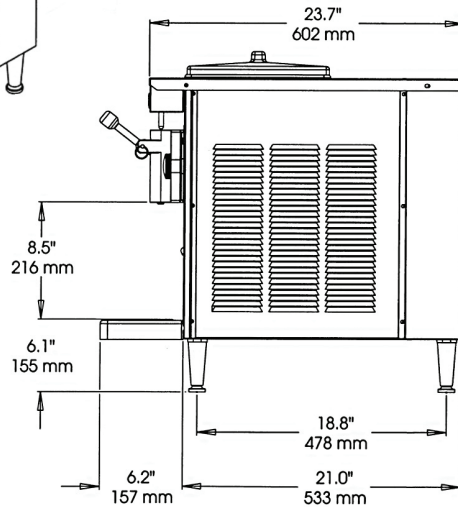
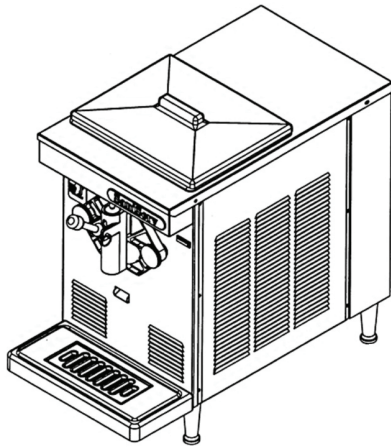

Minimum Wall Clearance
Both Sides and Back -
6 inches (152 mm)

ELECTRICAL				WIDTH	HEIGHT	DEPTH	WEIGHT	VOLUME
VOLTS	Hz	Ph.	Amps	INCHES (MM)	INCHES (MM)	INCHES (MM)	LBS. (Kg)	CU FT. (cu. m.)
115	60	1	15	14 (356)	25.4 (645)	23.7 (602)	145 (66)	
Shipping Specifications				22.5 (571)	31.5 (800)	34.5 (876)	185 (84)	8.6 (.25)

Specifications:

Cooling System:
Air Only

Dasher and Compressor Motor:
1/2 HP Dasher
1/2 HP Compressor

Refrigerant Type:
R404A

Listings:
UL, cUL, NSF

Features:

Evaporator and Mix Reservoir
Capacity:
7 Quarts (5.7 liters)

Dasher:
Heavy-Duty Stainless Steel with low friction scraper blades.

Controls:
Automatic consistency controls.

Warranty:

Parts 90 days
Compressor 1 year
Labor 30 days

Options:

Tune Up Kit
Machine Stand
Custom Graphic