



Profit from the Eagle Advantage®

# Specification Sheet

## Short Form Specifications

Eagle Griddle/Equipment Stand, model \_\_\_\_\_.  
 Top to be 16/304 stainless steel with 1/4" upturn on rear and sides. Constructed with uni-lok® patented gusset system with the gussets recessed into the hat channels to reduce lateral movement. Heavy gauge (galvanized, stainless steel) adjustable undershelf, 1 1/2"-diameter galvanized tubular legs with white metal adjustable bullet feet. Note: Units 72" and longer furnished with six legs.



unit shown with optional hardwood cutting board

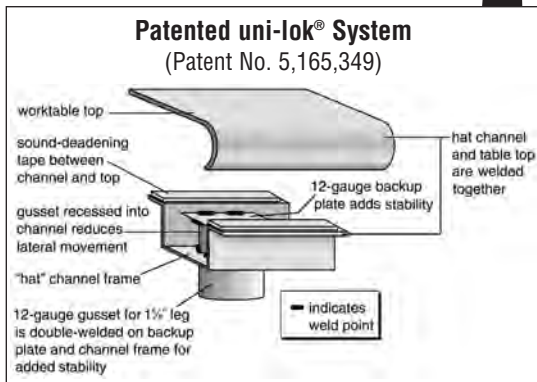

## Options / Accessories\*

- Hardwood cutting board
- Stainless steel plate shelf
- Casters
- Stainless steel bullet feet

\* Optional Worktable Stabilizer Bars (EG10.59) do not work with Griddle/Equipment Stands.

## EAGLE GROUP

100 Industrial Boulevard, Clayton, DE 19938-9905 USA  
 Phone: 302-653-3000 • Fax: 302-653-2065  
 www.eaglegrp.com

Foodservice Division: Phone 800-441-8440

MHC/Retail Display Divisions: Phone 800-637-5100

For custom configuration or fabrication needs, contact our SpecFAB® Division.

Phone: 302-653-3000 • Fax: 302-653-3091 • e-mail: specfab@eaglegrp.com

Item No.: \_\_\_\_\_  
 Project No.: \_\_\_\_\_  
 S.I.S. No.: \_\_\_\_\_

## Griddle/Equipment Stands

### MODELS:

- |                                   |                                   |                                   |                                  |
|-----------------------------------|-----------------------------------|-----------------------------------|----------------------------------|
| <input type="checkbox"/> T2424GS  | <input type="checkbox"/> T2484SGS | <input type="checkbox"/> T3072GS  | <input type="checkbox"/> 307109  |
| <input type="checkbox"/> T2424SGS | <input type="checkbox"/> T2496GS  | <input type="checkbox"/> T3072SGS | <input type="checkbox"/> 307110  |
| <input type="checkbox"/> T2436GS  | <input type="checkbox"/> T2496SGS | <input type="checkbox"/> T3084GS  | <input type="checkbox"/> APS1    |
| <input type="checkbox"/> T2436SGS | <input type="checkbox"/> T3024GS  | <input type="checkbox"/> T3084SGS | <input type="checkbox"/> APS2    |
| <input type="checkbox"/> T2448GS  | <input type="checkbox"/> T3024SGS | <input type="checkbox"/> T3096GS  | <input type="checkbox"/> APS3    |
| <input type="checkbox"/> T2448SGS | <input type="checkbox"/> T3036GS  | <input type="checkbox"/> T3096SGS | <input type="checkbox"/> APS4    |
| <input type="checkbox"/> T2460GS  | <input type="checkbox"/> T3036SGS | <input type="checkbox"/> 313970   | <input type="checkbox"/> APS5    |
| <input type="checkbox"/> T2460SGS | <input type="checkbox"/> T3048GS  | <input type="checkbox"/> 307105   | <input type="checkbox"/> APS6    |
| <input type="checkbox"/> T2472GS  | <input type="checkbox"/> T3048SGS | <input type="checkbox"/> 307106   | <input type="checkbox"/> APS7    |
| <input type="checkbox"/> T2472SGS | <input type="checkbox"/> T3060GS  | <input type="checkbox"/> 307107   | <input type="checkbox"/> APS8    |
| <input type="checkbox"/> T2484GS  | <input type="checkbox"/> T3060SGS | <input type="checkbox"/> 307108   | <input type="checkbox"/> CAH4-SB |
|                                   |                                   |                                   | <input type="checkbox"/> CAH6-SB |

### Tabletop

- Patented uni-lok® gusset system (patent #5,165,349): gussets are recessed into hat channel, reducing lateral movement.
- Highly-polished 16 gauge type 304 stainless steel top with 1/4" (32mm) upturn on rear and both ends.

### Adjustable Undershelf

- Heavy gauge galvanized or stainless steel, with gusset welded on each corner.

### Legs

- Galvanized or stainless steel.
- 1 1/2" (41mm)-diameter.
- Adjustable white metal feet.

### Optional Hardwood Cutting Board

- Laminated, 1/4" (32mm)-thick, full length of stand, 8" (203mm)-wide.
- Complete with 1" (25mm) OD stainless steel tubular supports integrally welded to adjustable stainless steel sleeve assembly.
- Board adjustment range is 8 1/2" (216mm) at lowest point to maximum of 15 1/2" (394mm).

### Optional Plate Shelf

- Full length of stand, 8" (203mm)-wide.
- 18 gauge stainless steel.
- Adjustable height.
- Must be ordered in conjunction with cutting board.

### Certifications / Approvals



### AUTOQUOTES



EG10.27 Rev. 08/11

Spec sheets available for viewing, printing or downloading from our online literature library at [www.eaglegrp.com](http://www.eaglegrp.com)

Eagle Foodservice Equipment, Eagle MHC, SpecFAB®, and Retail Display are divisions of Eagle Group. ©2011 by the Eagle Group

The Boelter Companies, Inc.



Profit from the Eagle Advantage®

Item No.: \_\_\_\_\_  
 Project No.: \_\_\_\_\_  
 S.I.S. No.: \_\_\_\_\_

## Griddle/Equipment Stands

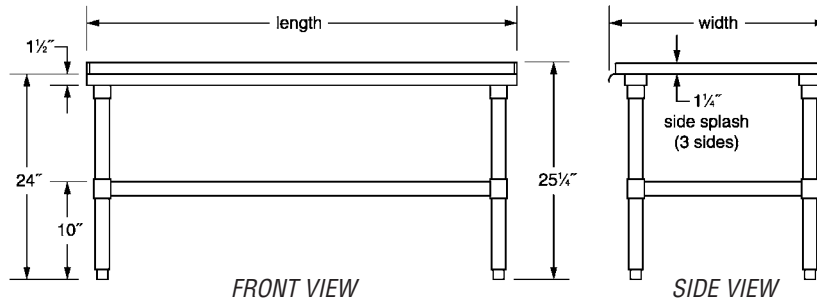

galvanized legs and undershelf model #	stainless legs and undershelf model #	# of legs	tabletop dimensions				weight capacities				weight	
			width in.	width mm	length in.	length mm	bullet lbs.	bullet kg	opt'l casters lbs.	opt'l casters kg	lbs.	kg
T2424GS	T2424SGS	4	24 3/8"	619	24 3/8"	619	320	145.1	180	81.6	48	21.8
T2436GS	T2436SGS	4	24 3/8"	619	36 3/8"	924	480	217.7	270	122.5	54	24.5
T2448GS	T2448SGS	4	24 3/8"	619	48 3/8"	1229	640	290.3	360	163.3	62	28.1
T2460GS	T2460SGS	4	24 3/8"	619	60 3/8"	1534	800	362.9	450	204.1	74	33.6
T2472GS	T2472SGS	6	24 3/8"	619	72 3/8"	1838	960	435.5	540	244.9	86	39.0
T2484GS	T2484SGS	6	24 3/8"	619	84 3/8"	2143	1120	508.0	630	285.8	99	44.9
T2496GS	T2496SGS	6	24 3/8"	619	96 3/8"	2448	1280	580.6	720	326.6	120	54.4
T3024GS	T3024SGS	4	30 3/8"	772	24 3/8"	619	400	181.4	225	102.1	48	21.8
T3036GS	T3036SGS	4	30 3/8"	772	36 3/8"	914	600	272.2	338	153.3	55	24.9
T3048GS	T3048SGS	4	30 3/8"	772	48 3/8"	1229	800	362.9	450	204.1	71	32.2
T3060GS	T3060SGS	4	30 3/8"	772	60 3/8"	1534	1000	453.6	563	255.4	83	37.6
T3072GS	T3072SGS	6	30 3/8"	772	72 3/8"	1838	1200	544.3	675	306.2	96	43.6
T3084GS	T3084SGS	6	30 3/8"	772	84 3/8"	2143	1400	635.0	788	357.4	112	50.8
T3096GS	T3096SGS	6	30 3/8"	772	96 3/8"	2448	1600	725.8	900	408.2	125	56.7

### Optional Hardwood Cutting Board

model #	width in.	width mm	length in.	length mm	weight lbs.	weight kg
313970	8"	203	24"	610	12	5.4
307105	8"	203	36"	914	16	7.3
307106	8"	203	48"	1219	21	9.5
307107	8"	203	60"	1524	26	11.8
307108	8"	203	72"	1829	31	14.1
307109	8"	203	84"	2134	39	17.6
307110	8"	203	96"	2438	46	20.9

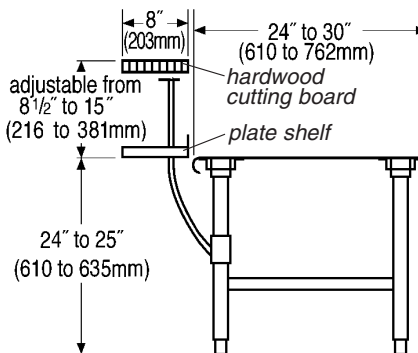

casters

### Optional Plate Shelf

model #	width in.	width mm	length in.	length mm	weight lbs.	weight kg
APS2	8"	203	24"	610	5	2.3
APS3	8"	203	36"	914	6	2.7
APS4	8"	203	48"	1219	7	3.2
APS5	8"	203	60"	1524	11	5.0
APS6	8"	203	72"	1829	13	5.8
APS7	8"	203	84"	2134	16	7.3
APS8	8"	203	96"	2438	20	9.0

dimensions of unit with optional hardwood cutting board and plate shelf

### Optional Zinc Swivel Casters

5" (127mm)-diameter. 200 lb. (90.7 kg) weight capacity per caster. Heavy duty. Resilient tread.

model #	description
CAH4-SB	set of 4 (2 w/brake)
CAH6-SB	set of 6 (3 w/brake)

### EAGLE GROUP

100 Industrial Boulevard, Clayton, DE 19938-9905 USA

Phone: 302-653-3000 • Fax: 302-653-2065

www.eaglegrp.com

Foodservice Division: Phone 800-441-8440

MHC/Retail Display Divisions: Phone 800-637-5100

Spec sheets available for viewing, printing or downloading from our online literature library at [www.eaglegrp.com](http://www.eaglegrp.com)

Although every attempt has been made to ensure the accuracy of the information provided, we cannot be held responsible for typographical or printing errors. Information and specifications are subject to change without notice. Please confirm at time of order.