

**HEATED HOLDING****VULCAN****VCW SERIES  
FIRST-IN FIRST-OUT CHIP WARMER**

Model VCW46

**SPECIFICATIONS**

First-in, first-out high volume chip warmer Vulcan Model Nos. VCW26 and VCW46. VCW26 holds 26 gallons of chips while model VCW46 holds 46 gallons of chips. Internal baffles to minimize chip breakage. Fan circulates air for even heat distribution and quick heating of the chips. Fully removable front panel and bottom baffle allows for full access to the interior of the unit for quick and easy cleaning. Top doors, front panel and bottom baffle are removable without tools. Top filled doors open wide for easy loading of chips. Front door serves as a shelf when scooping chips and the sloped front allows secure closure and easy opening. Unit comes with illuminated on/off switch and adjustable rear-mounted thermostat (90°-190°F). Durable 20 gauge stainless steel construction with 12 gauge front door hinge and high density insulation. Furnished with power cord and a NEMA 5-15 plug, 120 volt, 1500 watts, 12.5 amps. Lifetime warranty on heating element.

**Exterior Dimensions:**

VCW26: 26½"w x 30½"d x 30½"h

VCW46: 26½"w x 30½"d x 38"h

UL listed. UL listed to Canadian safety standards, Classified by UL to NSF Std. #4.

- **VCW26** 26 Gallon Chip Warmer
- **VCW46** 46 Gallon Chip Warmer

**STANDARD FEATURES**

- Capacity 26 gallons for model VCW26 and 46 gallons for model VCW46.
- Door opens creating a shelf for scooping chips.
- Sloping front of unit allows secure closure and easy opening.
- Wide top opening doors for easy loading of chips.
- Fan circulates air for quick and even heating of chips.
- Internal baffle minimizes chip breakage.
- Fully removable front panel and bottom baffle for quick and easy cleaning of the unit.
- Top doors, front panel and bottom baffle are removable without tools.
- Durable 20 gauge stainless steel construction with high density insulation.
- 12 gauge front door hinge.
- Adjustable rear-mounted thermostat (90°-190°F).
- Illuminated on/off switch.
- 4"-5" adjustable legs.
- Lifetime warranty on heating elements.
- Furnished with power cord and a NEMA 5-15 plug.
- 120 volt, 1500 watts, 12.5 amps.

**VULCAN**

a division of ITW Food Equipment Group LLC

P.O. Box 696 ■ Louisville, KY 40201 ■ Toll-free: 1-800-814-2028 ■ Local: 502-778-2791 ■ Quote &amp; Order Fax: 1-800-444-0602



**VCW SERIES**  
FIRST-IN FIRST-OUT CHIP WARMER

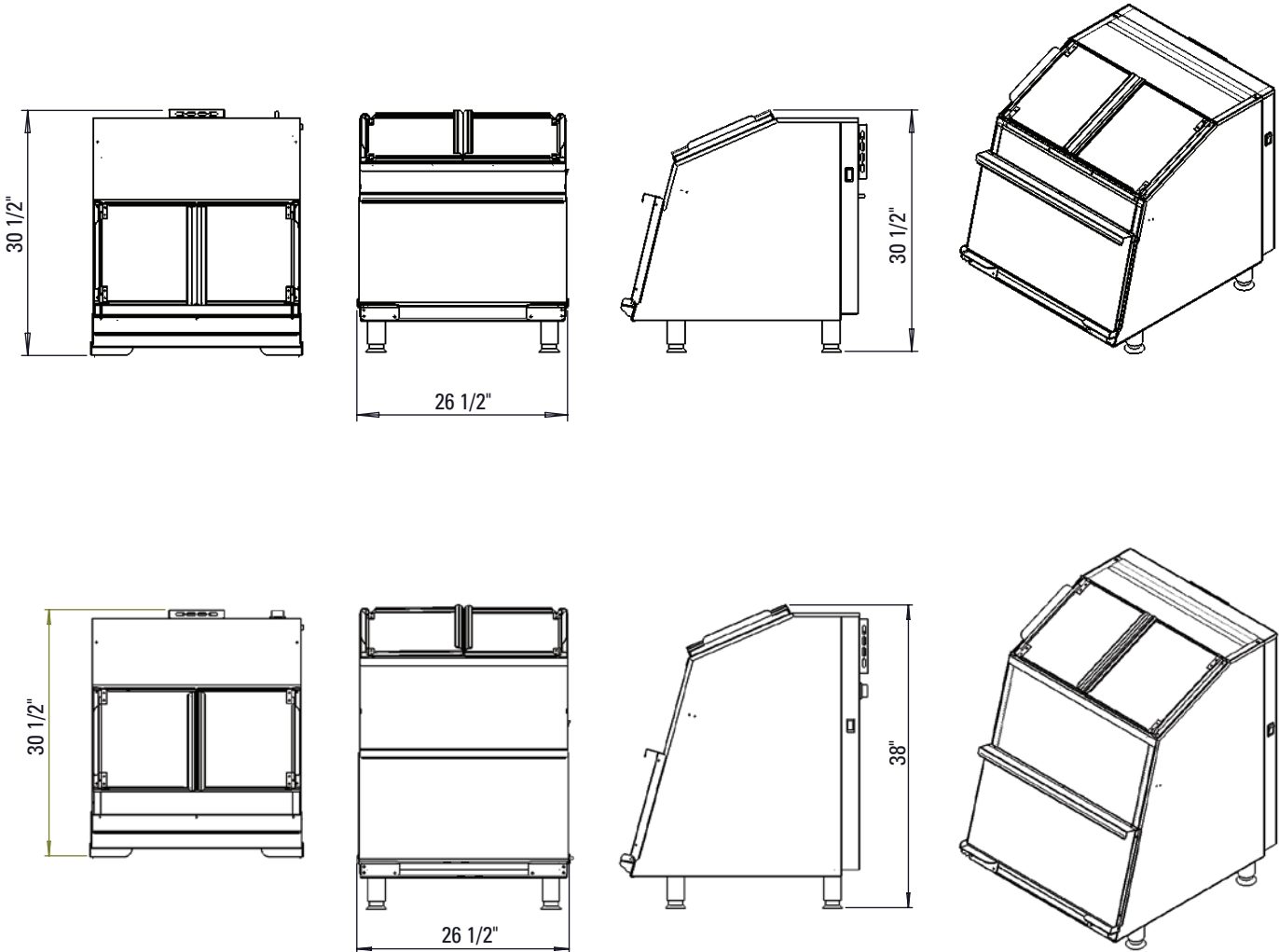

Model	Capacity	Dimensions			Shipping Weight	Electrical		
		High	Deep	Wide		Volts	Watts	Amps
<b>VCW26</b>	26 gallons	30½"	30½"	26½"	115 lbs.	120	1500	12.5
<b>VCW46</b>	46 gallons	38"	30½"	26½"	153 lbs.	120	1500	12.5

This appliance is manufactured for commercial use only and is not intended for home use.



a division of ITW Food Equipment Group LLC

P.O. Box 696 ■ Louisville, KY 40201 ■ Toll-free: 1-800-814-2028 ■ Local: 502-778-2791 ■ Quote & Order Fax: 1-800-444-0602